

1. Le système est compatible avec le system à rupture de pont thermique confort 50 qui fait partie aussi de EUROSYSTEM.
2. Verre: dormant: de 2 à 35,5 mm
ouvrant: de 2 à 45,5 mm
3. Vitrage au silicone ou avec des joints d'étanchéité préformés en EPDM.
4. Evacuation d'eau efficace du profilé ouvrant.
5. Chambre d'égalisation de pression importante pour une meilleure étanchéité à l'eau.
6. Joint central (EPDM ou TPE) largement dimensionné pour une étanchéité au vent et à l'eau plus performante.
7. Etanchéité étudiée pour éviter l'infiltration d'eau en dessous du joint central.
8. Drainage direct de la chambre d'égalisation de pression.
9. Fond de feuillure abaissée pour éviter le passage d'eau.
10. Equerre en inox, auto-serrante glissée dans les ailes, lèvre extérieure et frappe intérieure, assurant la planéité de l'onglet.
11. Profondeur modulaire:
 - dormant: 50 mm
 - ouvrant: 60 mm
12. Parcloses modulaires : hauteur de 22 mm, par étape de 2,5 mm au choix. A clipper, tubulaire ou montage frontal à l'aide de clips en PA.
Type : *Classic (rectangle)*, *Rustic* (décoratif) ou *Futuro* (arrondi).
13. Jonction angulaire à l'aide d'une équerre, identique dormant et ouvrant, avec tasseau excentrique, à sertir ou à goupiller.
14. Gorge pour quincailleries standardisée suivant normes européennes.
15. Joint acoustique.
16. Différentes combinaisons de dormants avec ouvrants pour intégrer les profils de finitions et ancrages.

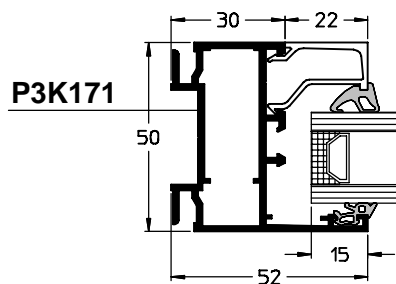

échelle : 50%

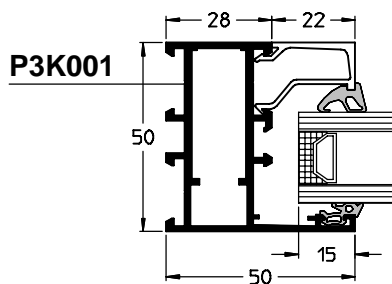
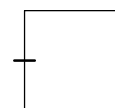
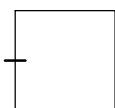
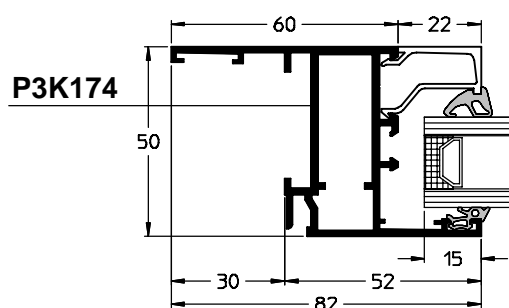
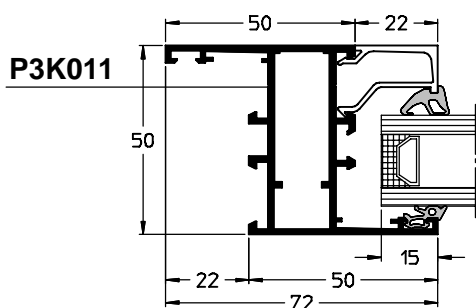
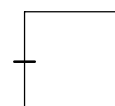
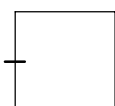

FU

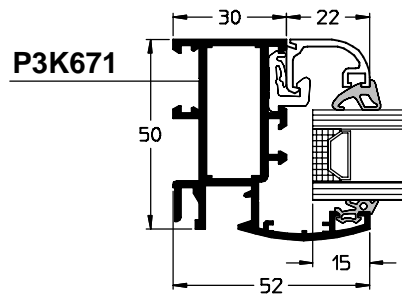
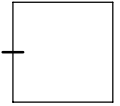

échelle : 50%

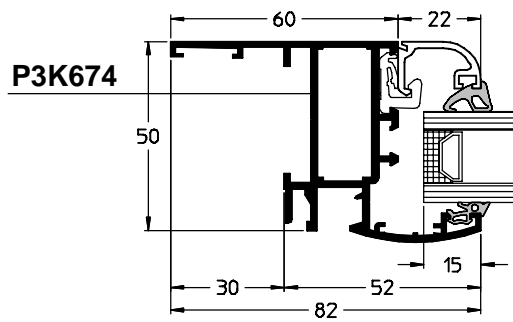
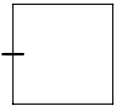

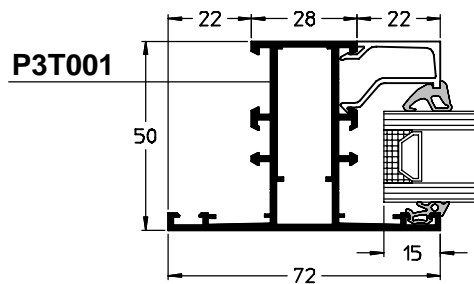
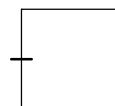

échelle : 50%

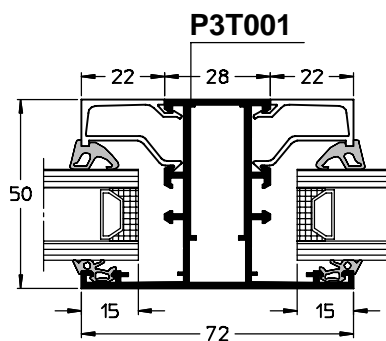
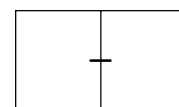

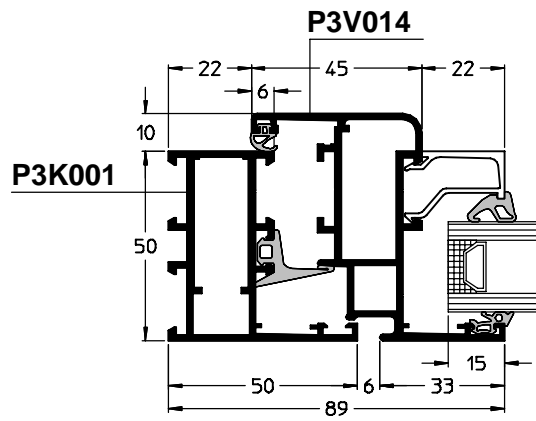
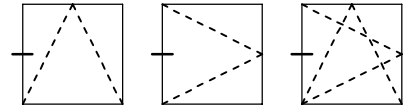

échelle : 50%

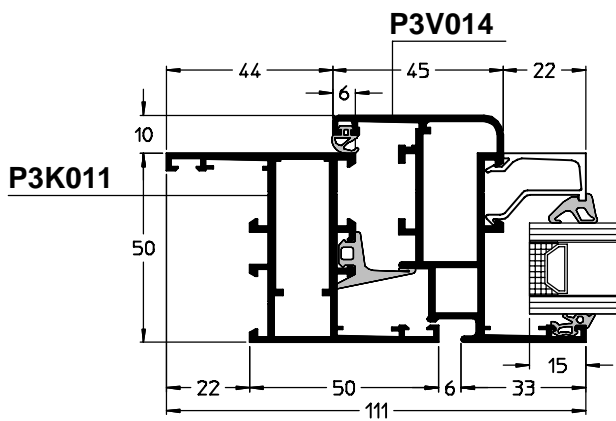
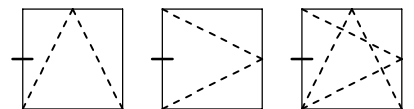

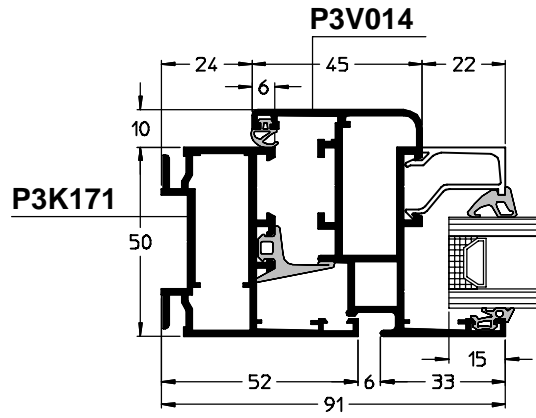
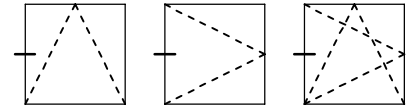

échelle : 50%

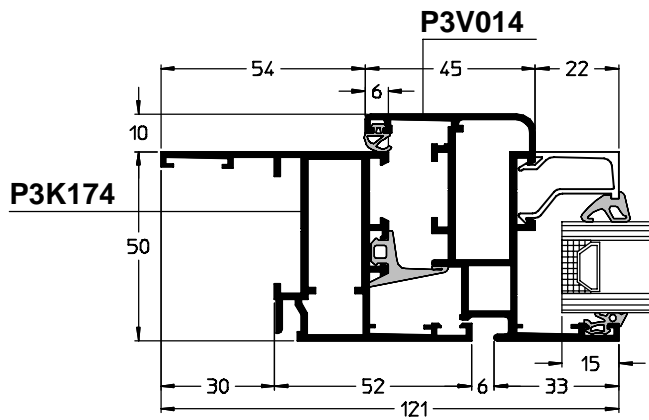
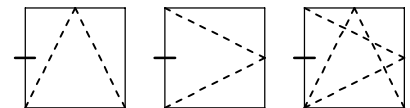

FU

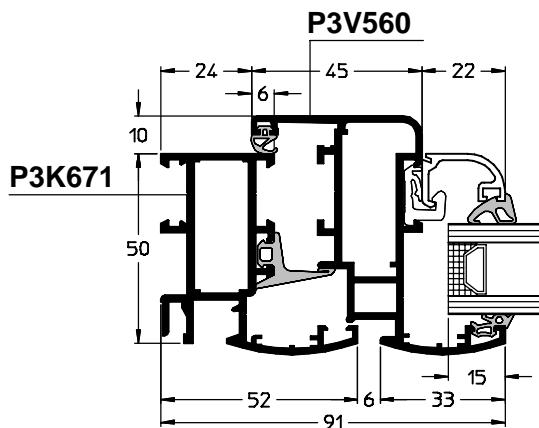
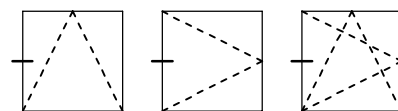

échelle : 50%

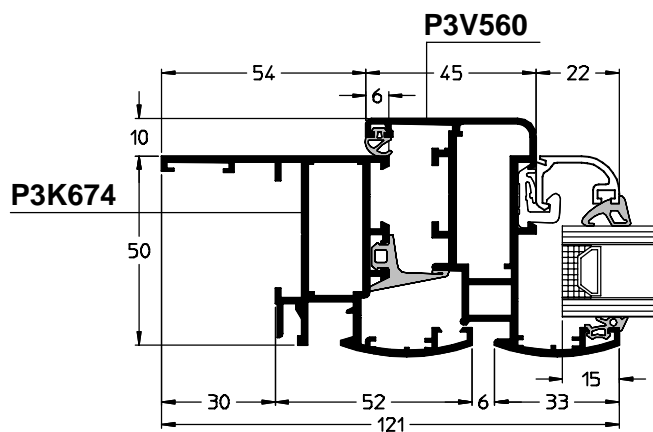
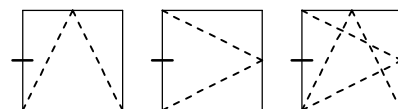

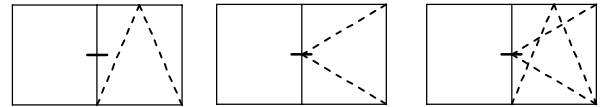
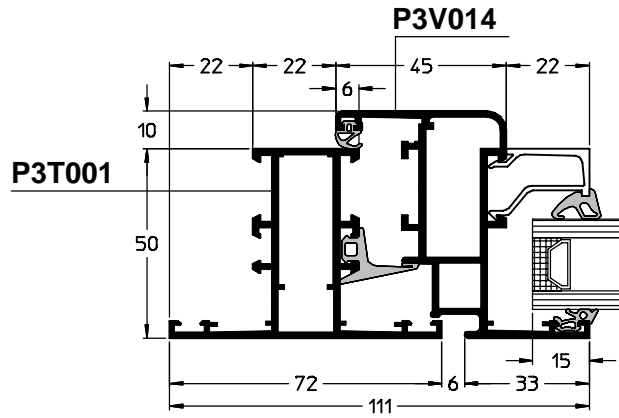
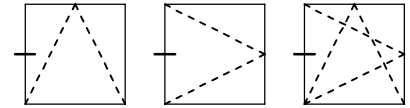

échelle : 50%

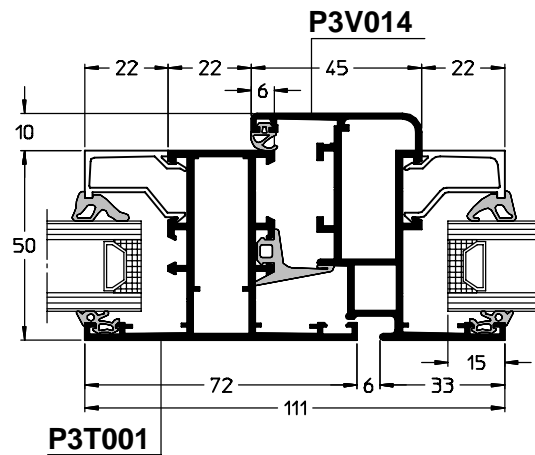

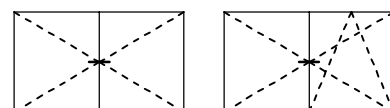
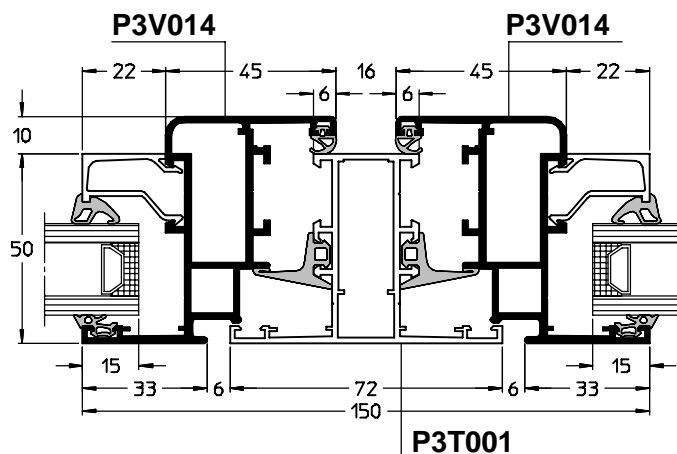
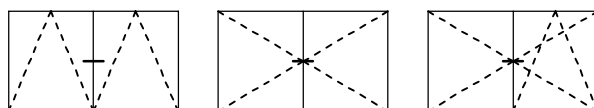

échelle : 50%

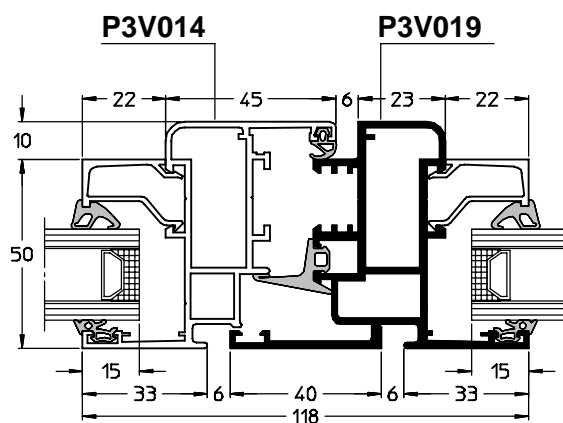
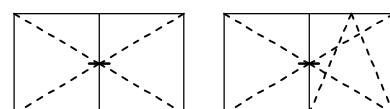
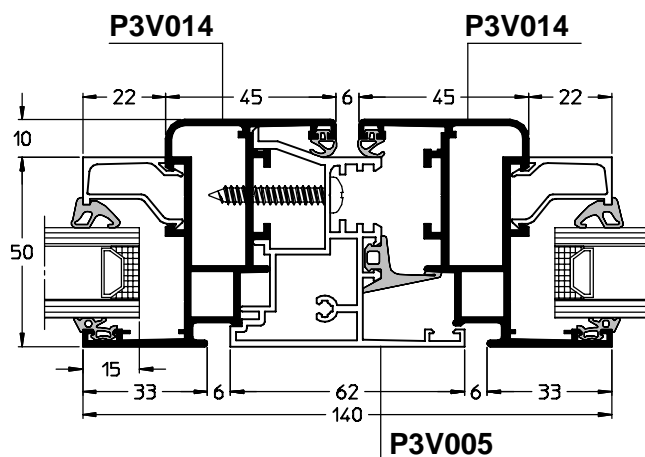

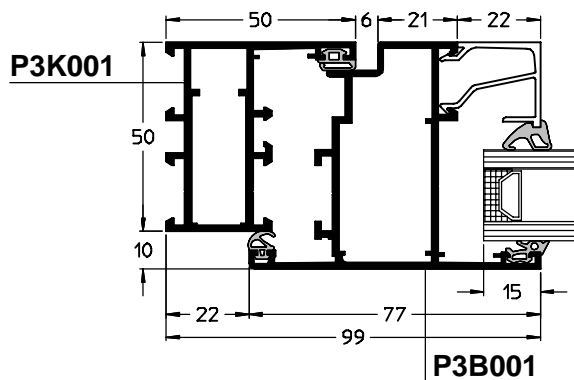
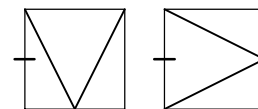

échelle : 50%

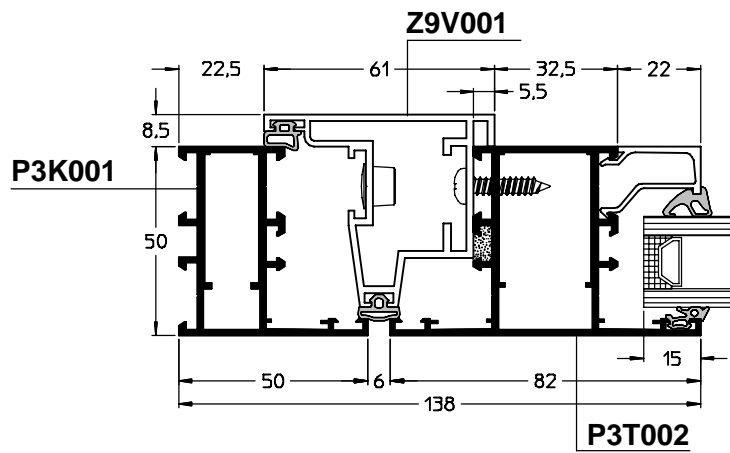
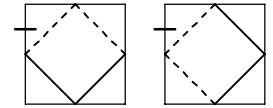

échelle : 50%

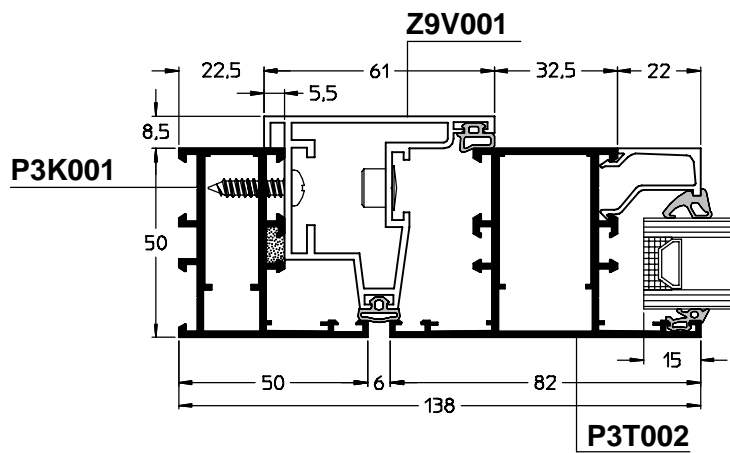
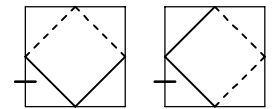

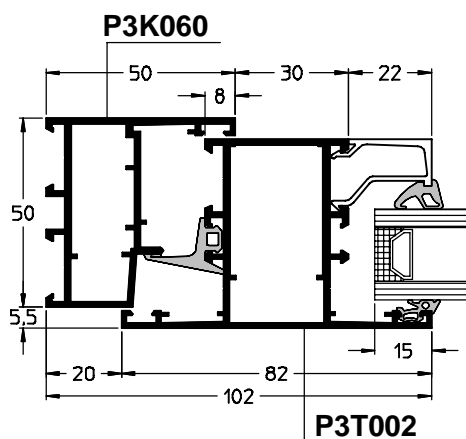
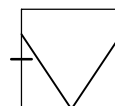

échelle : 50%

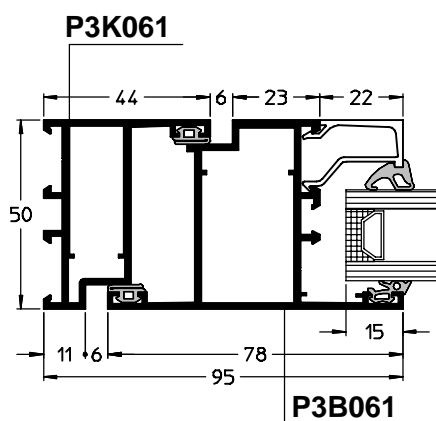
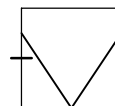

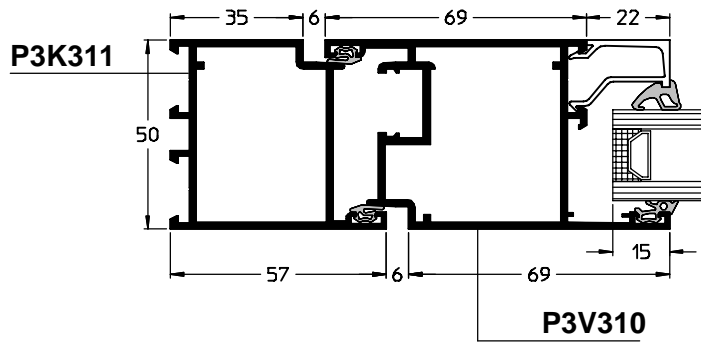
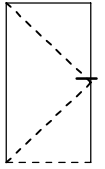

échelle : 50%

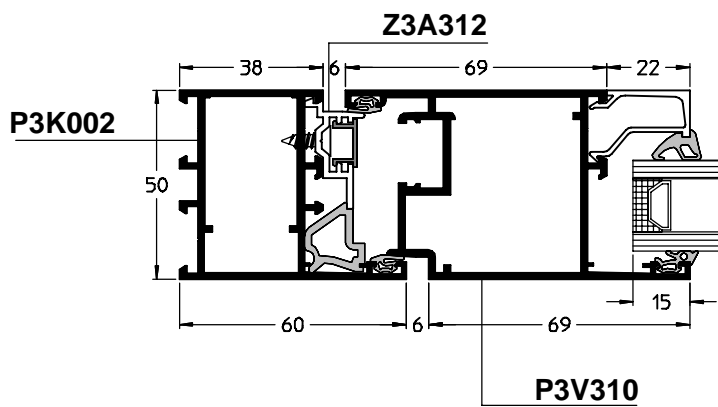
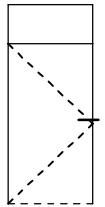

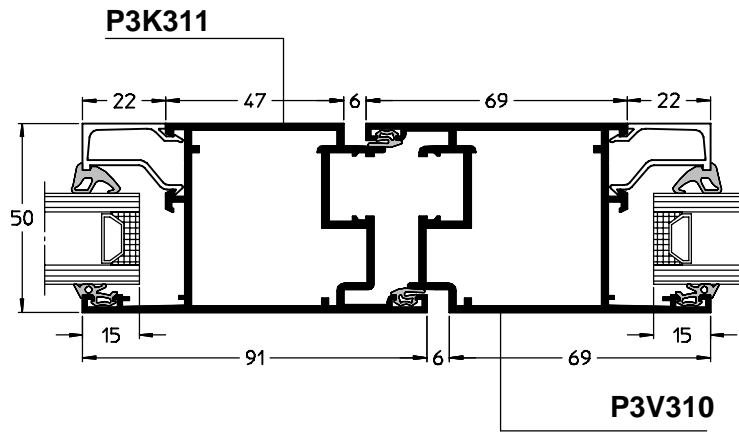
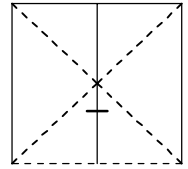

échelle : 50%

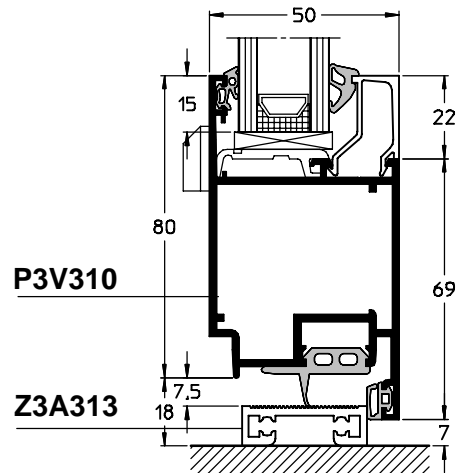
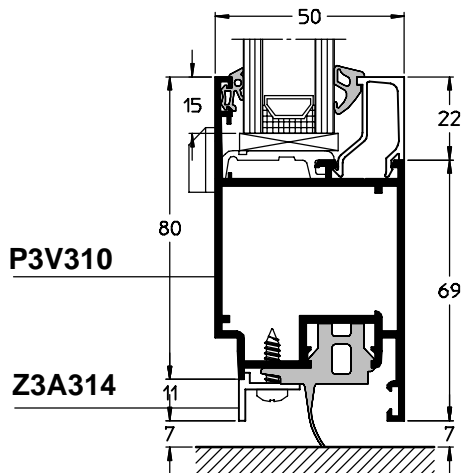
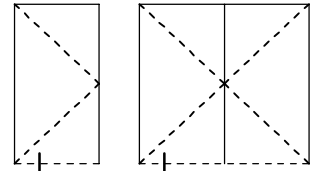

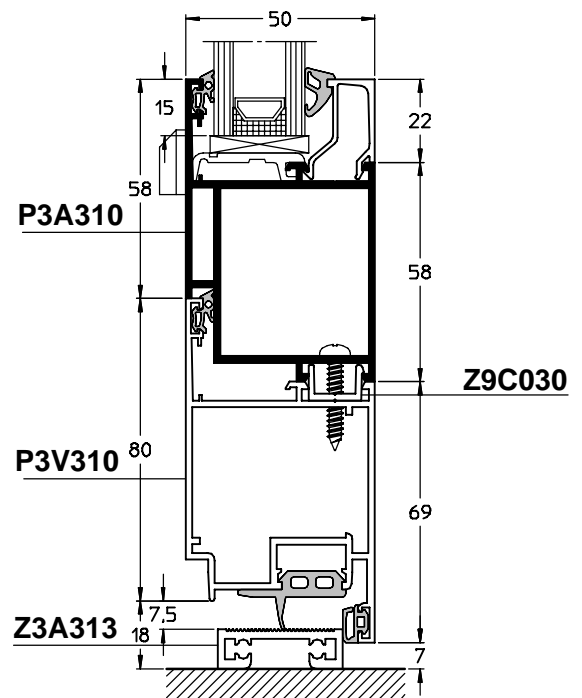
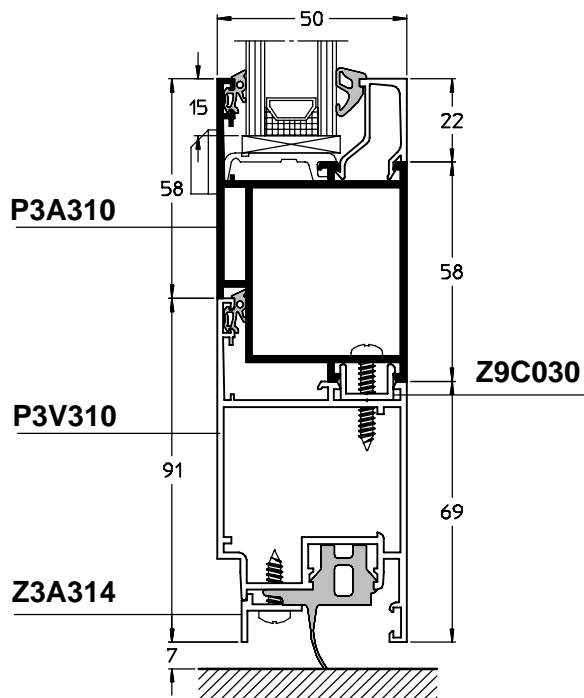
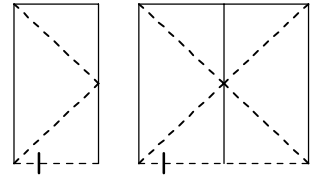

échelle : 50%

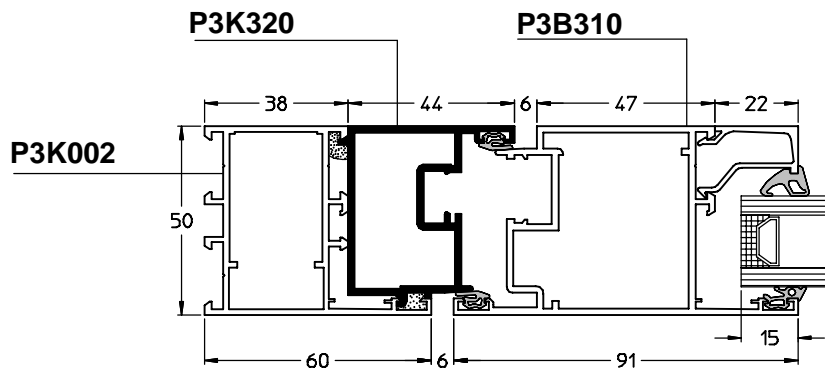
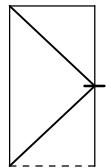
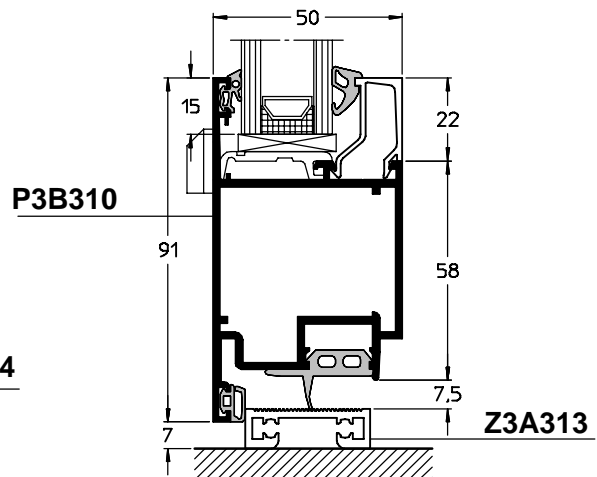
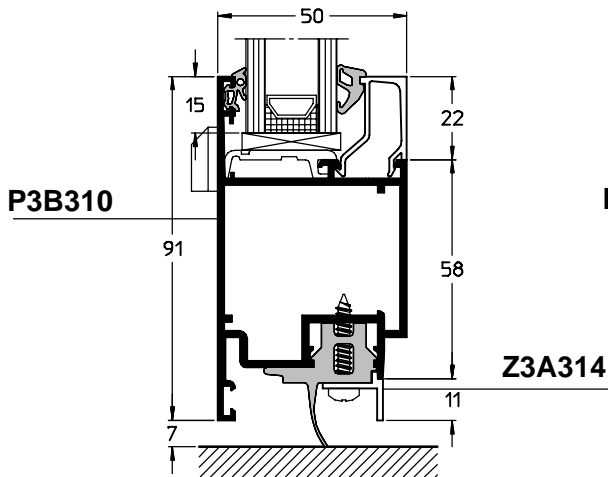
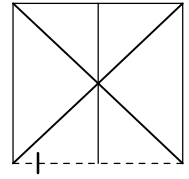
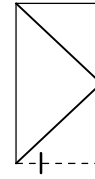

échelle : 50%

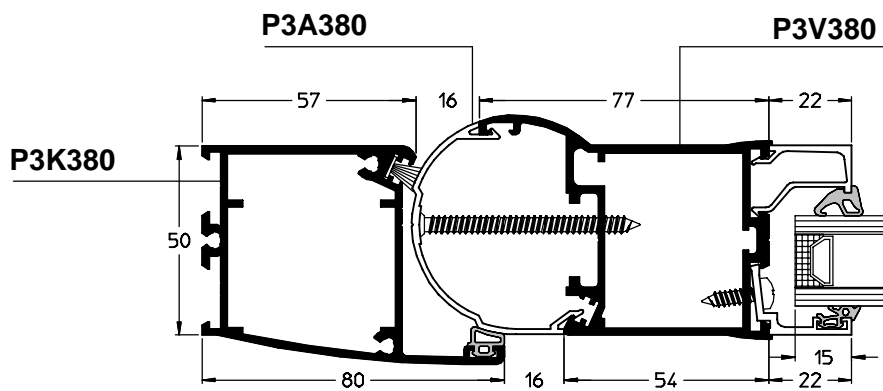
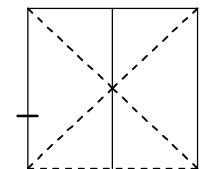
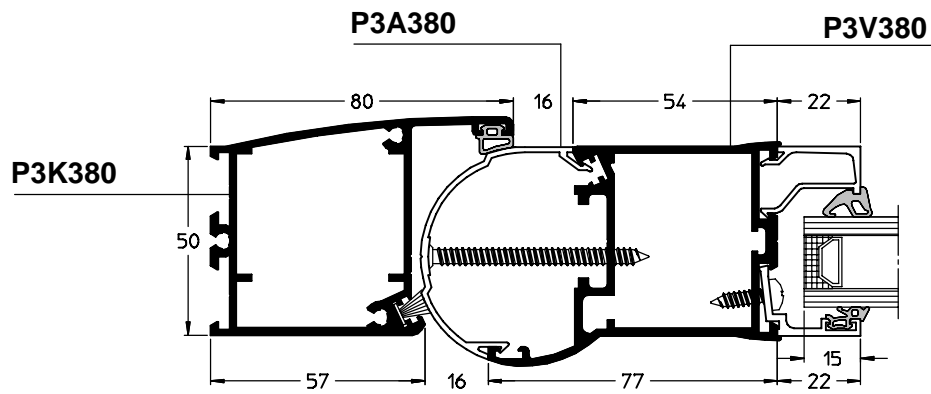
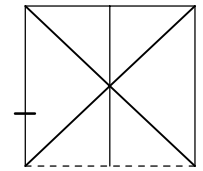

échelle : 50%

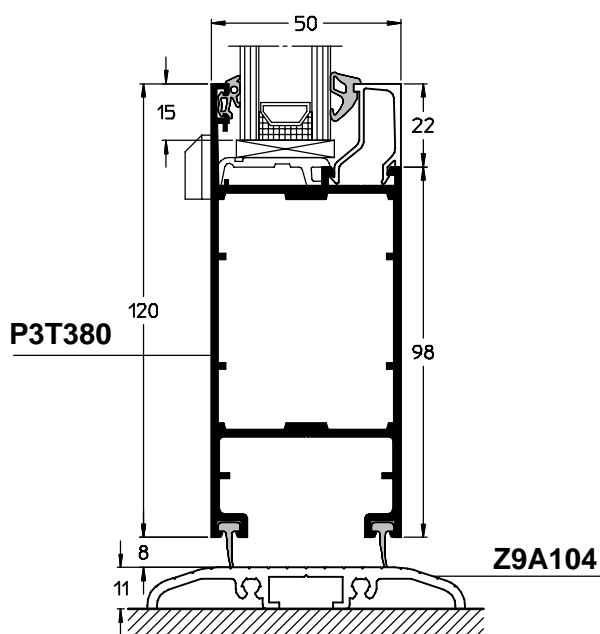
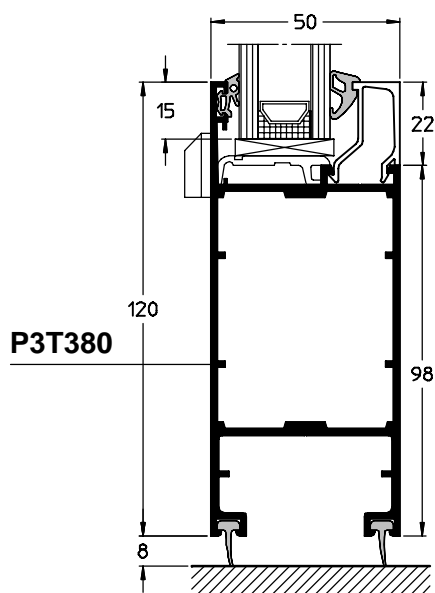
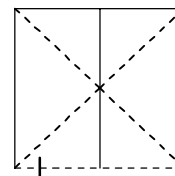

échelle : 50%

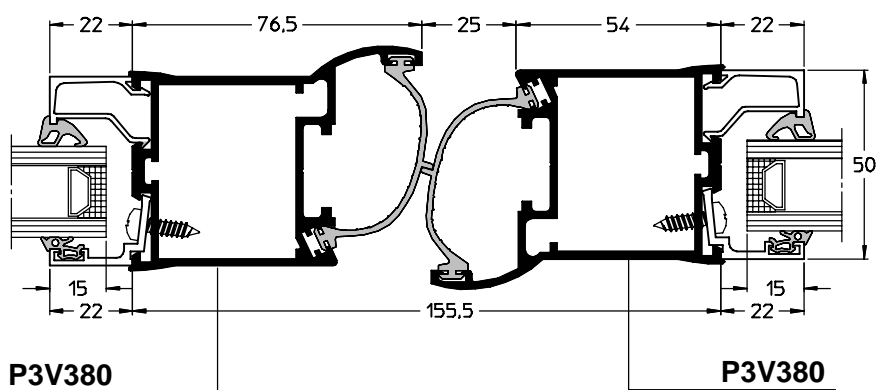
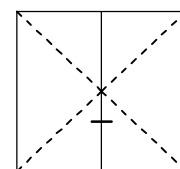
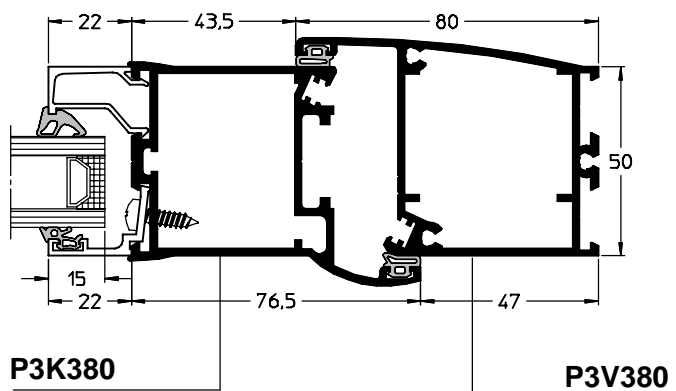
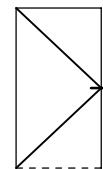

échelle : 50%

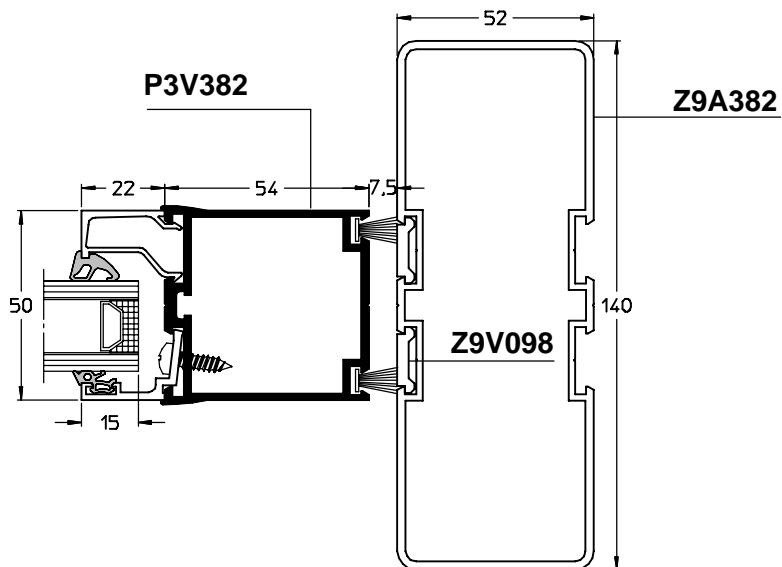
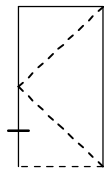
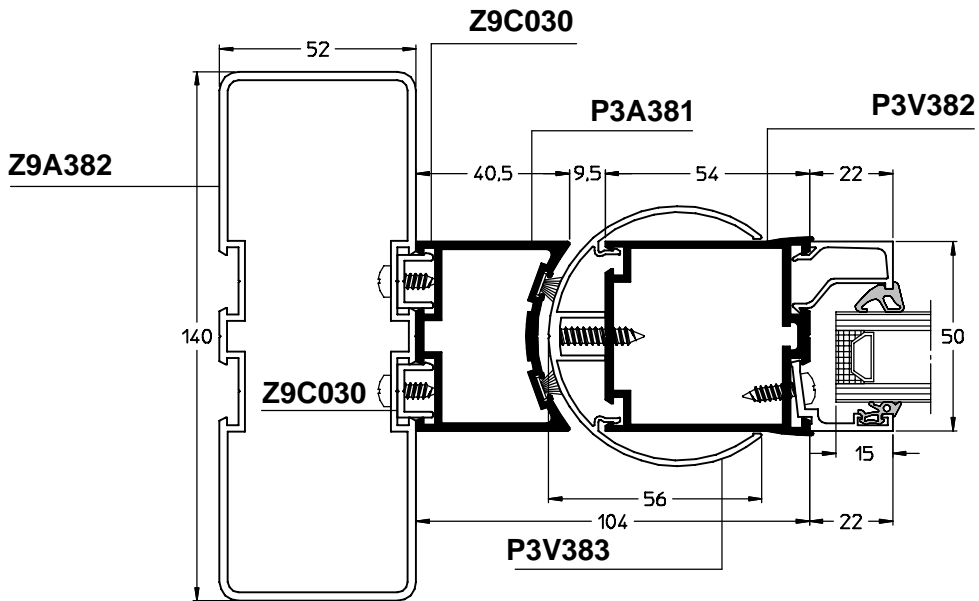
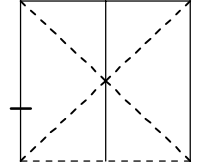

échelle : 50%

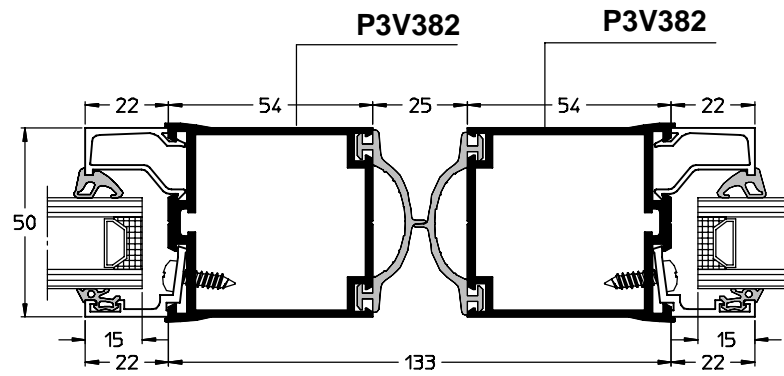
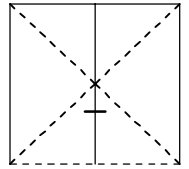

échelle : 50%

GTI

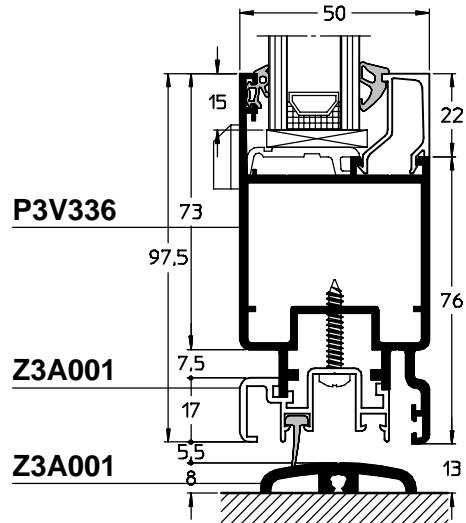
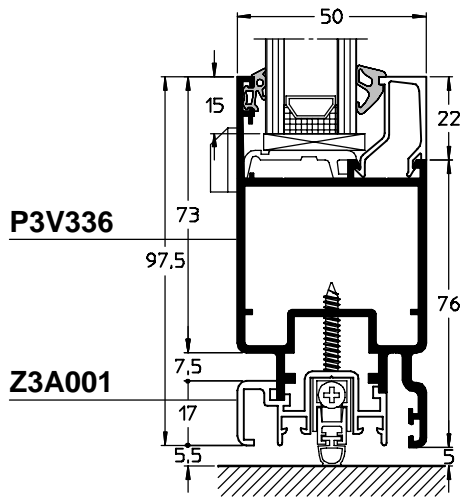
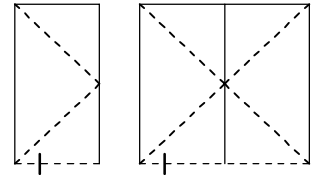

échelle : 50%

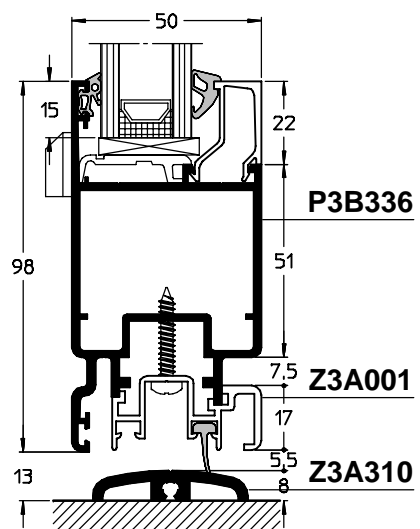
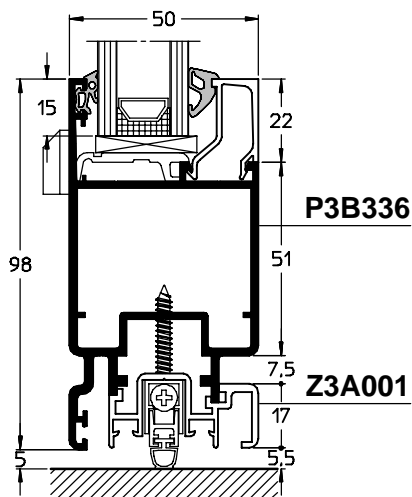
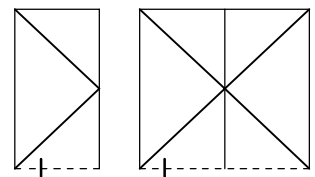

GTI

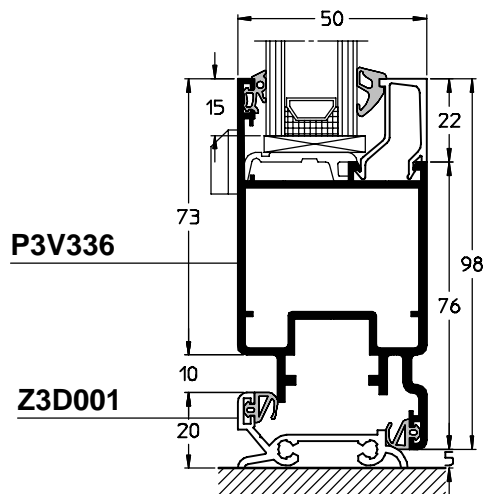
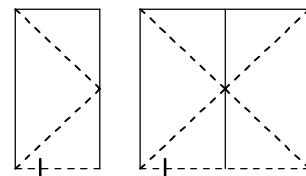

échelle : 50%

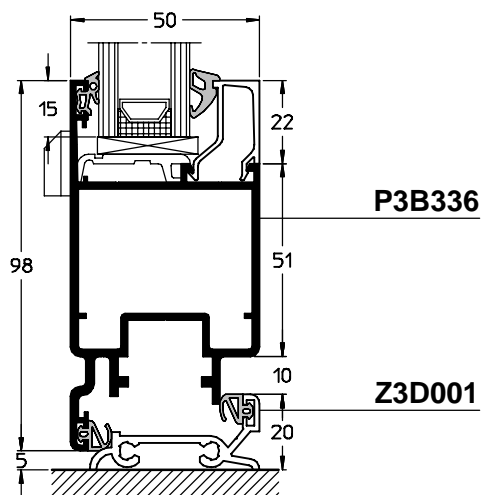
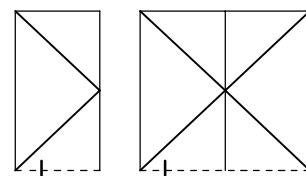

GTI

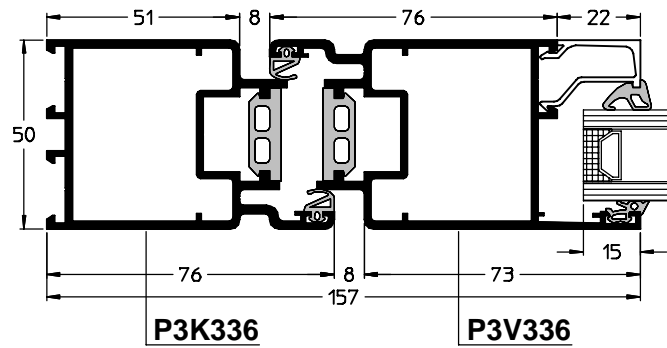
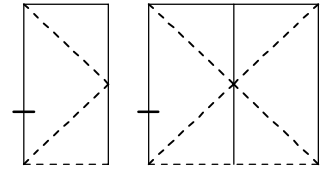

échelle : 50%

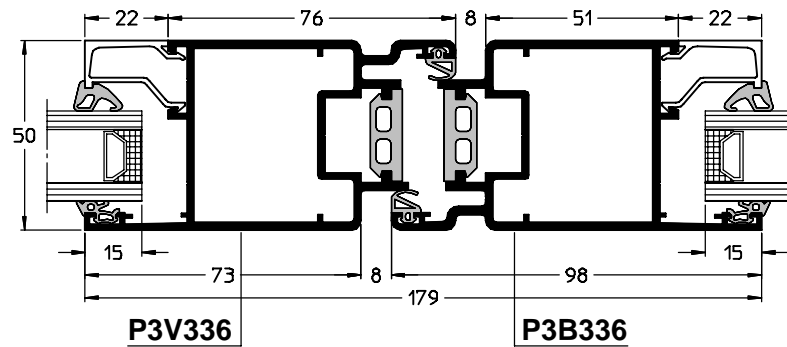
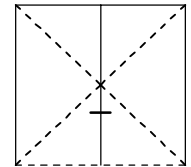

GTI

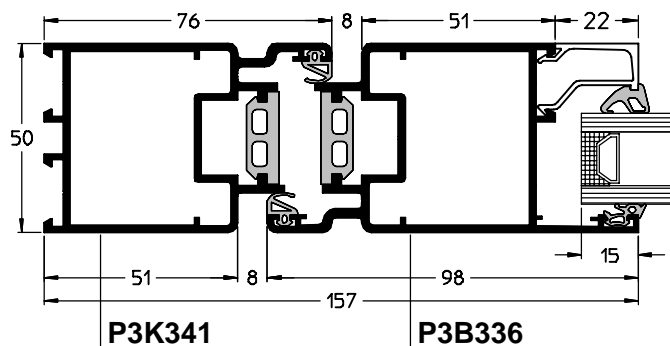
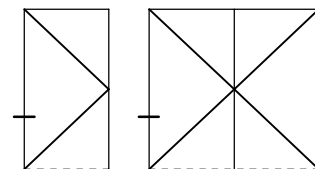

échelle : 50%

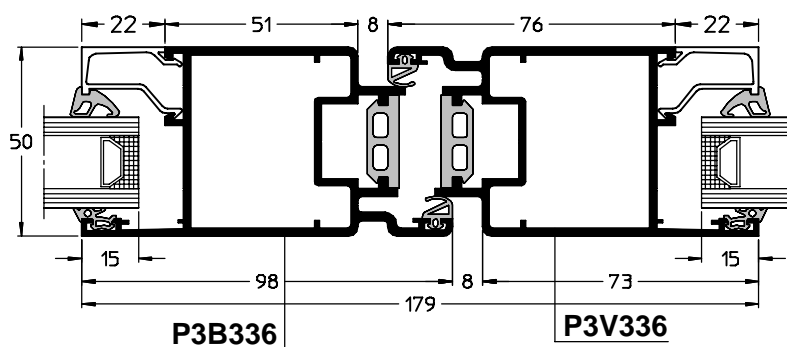
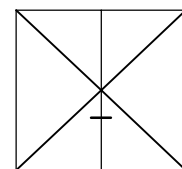

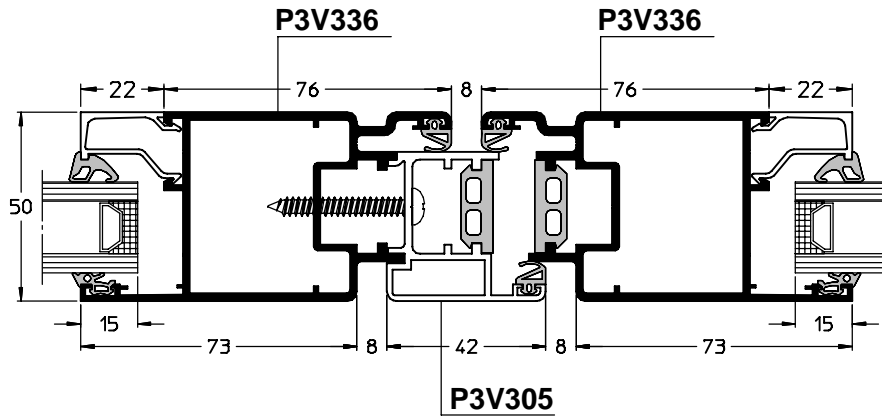
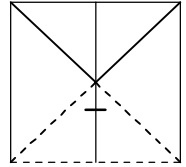

échelle : 50%

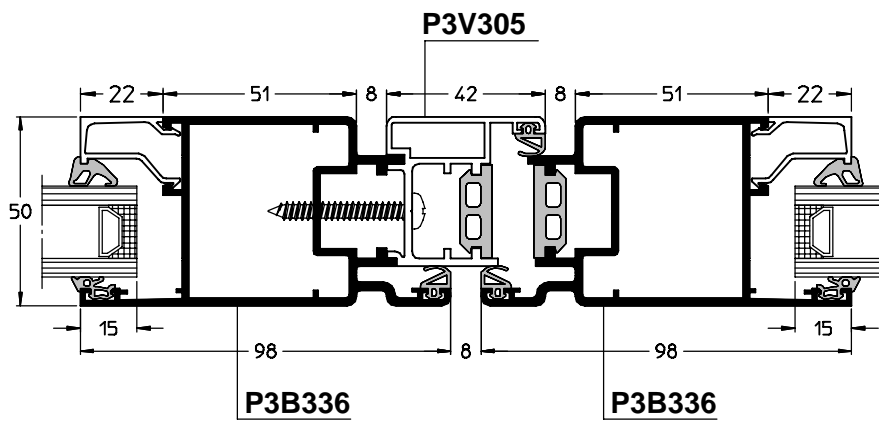
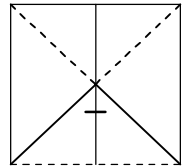

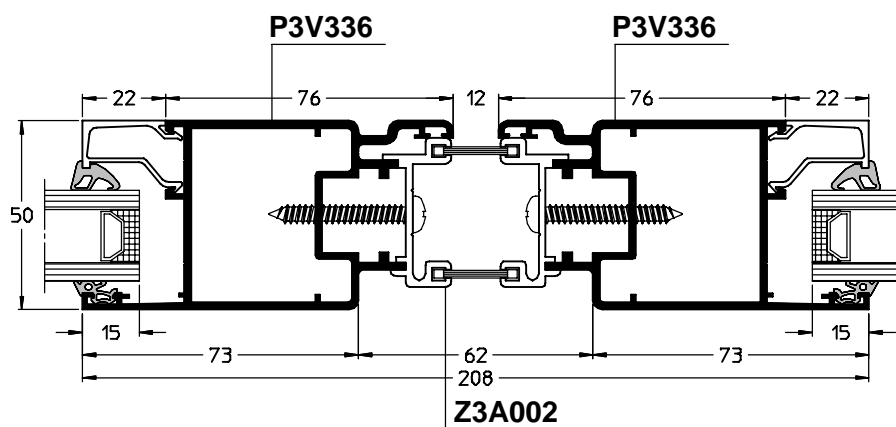
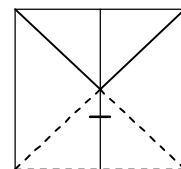

échelle : 50%

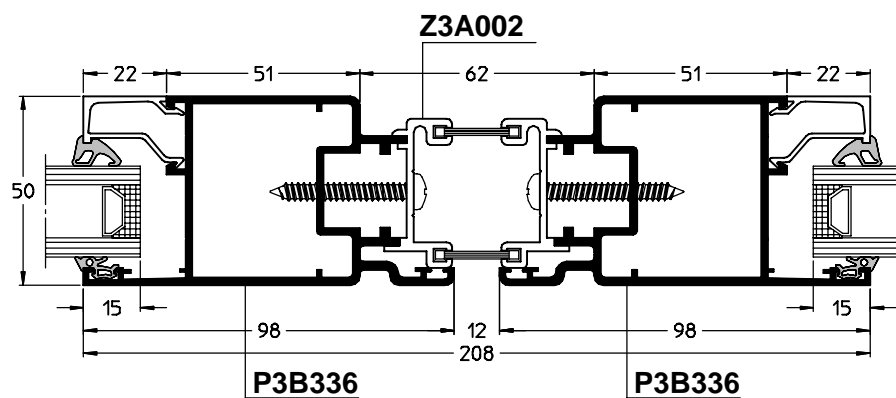
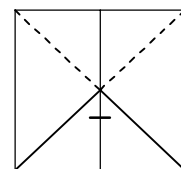

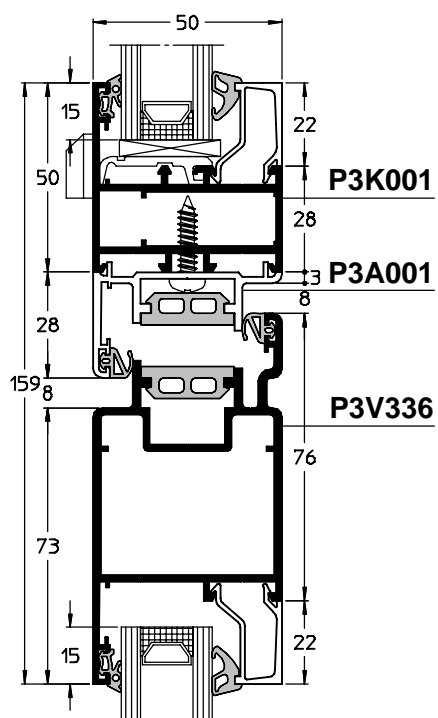
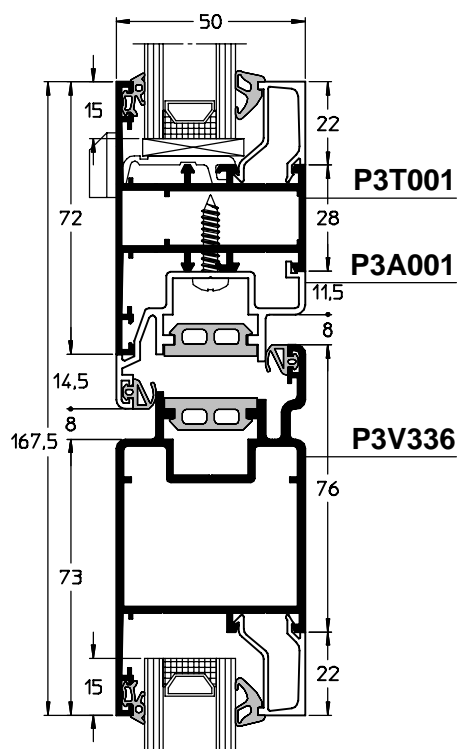
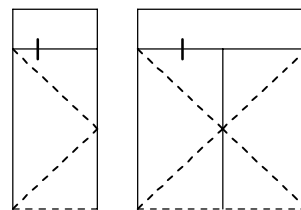

échelle : 50%

GTI

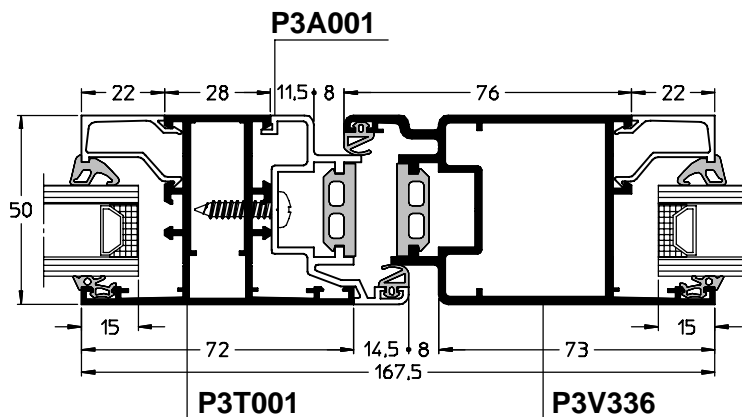
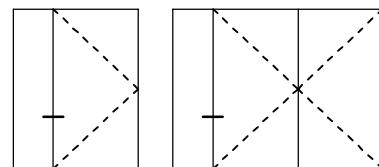

échelle : 50%

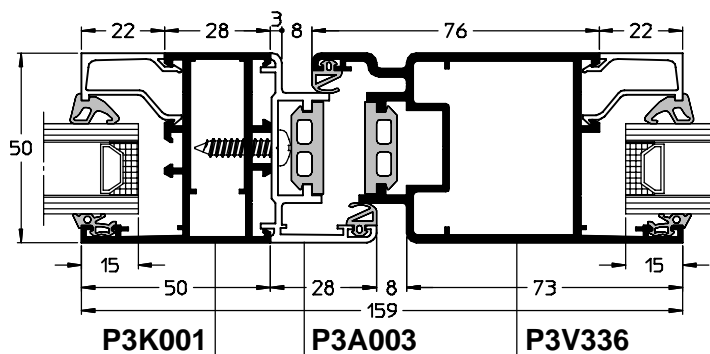
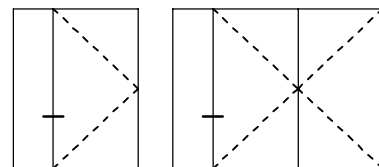

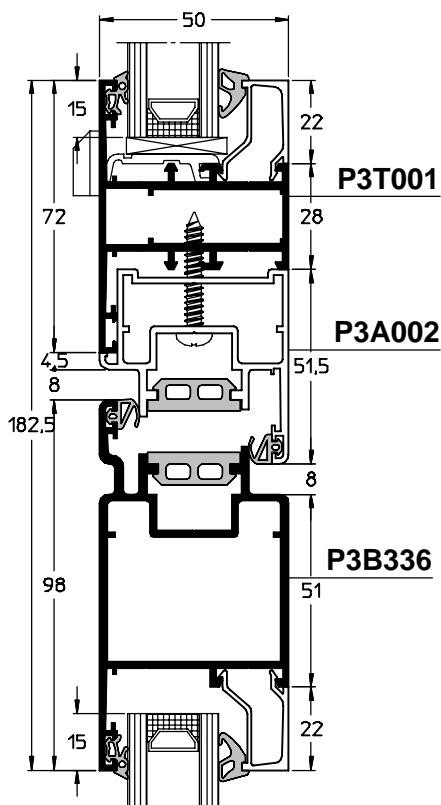
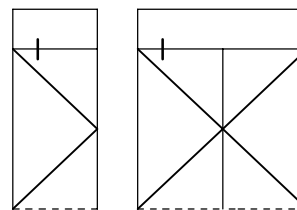

échelle : 50%

GTI

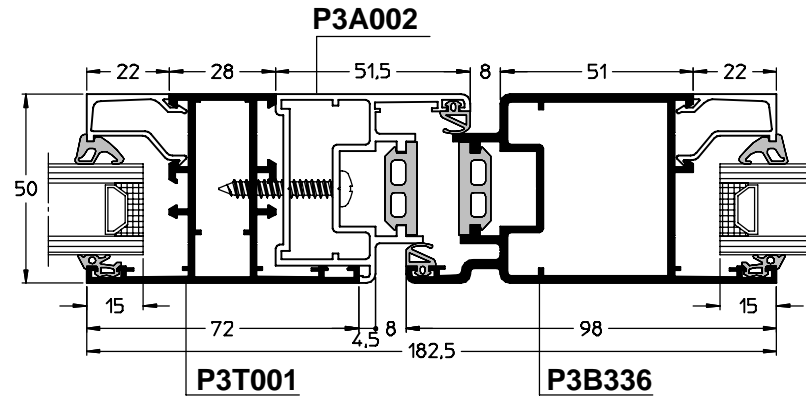
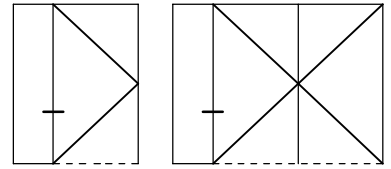

échelle : 50%

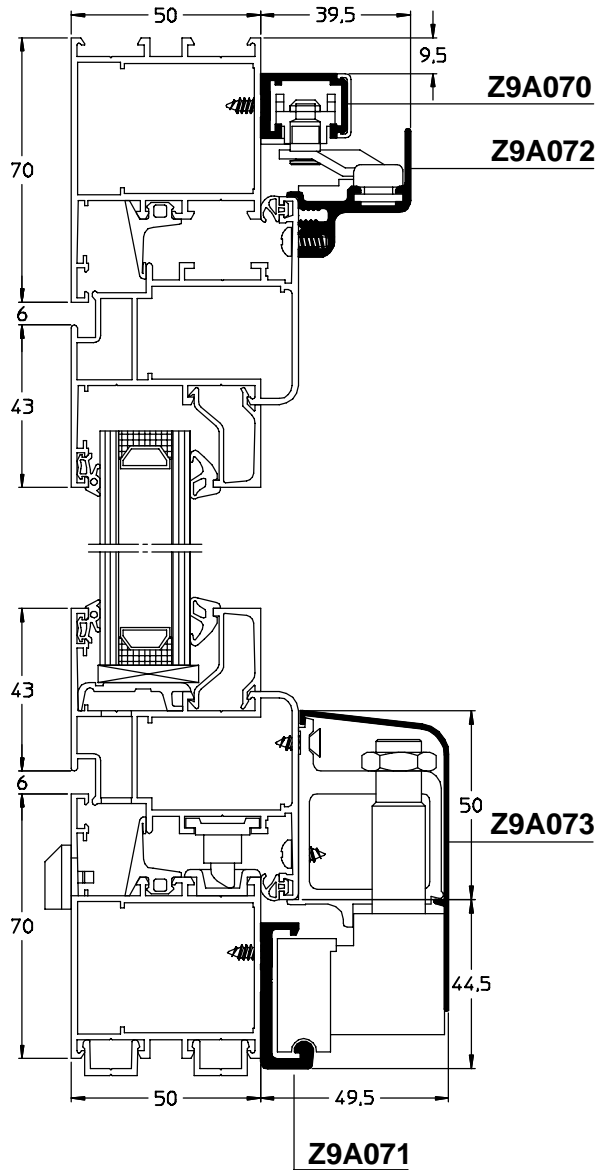
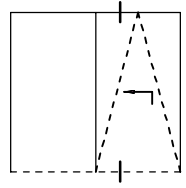

échelle : 50%

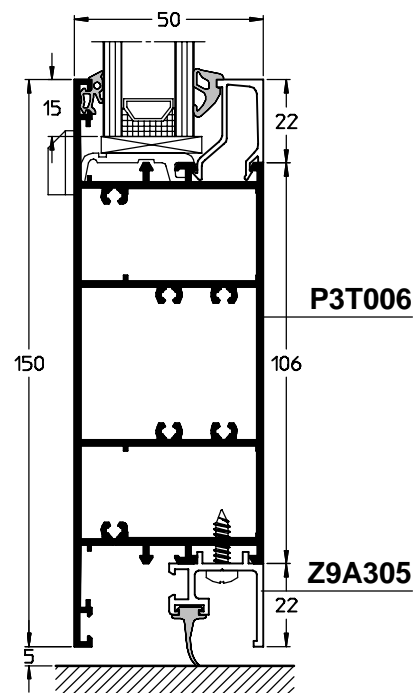
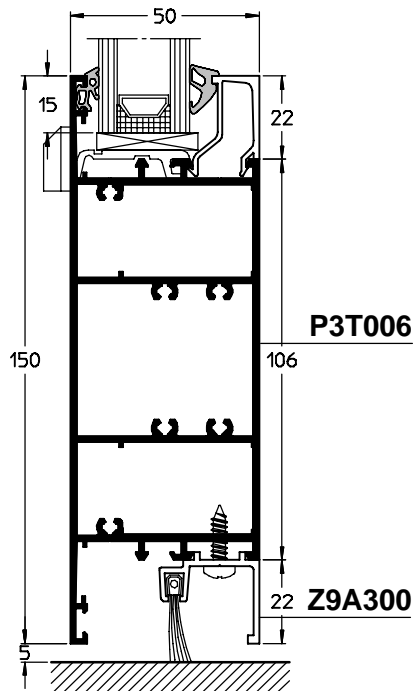
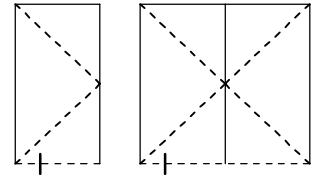

échelle : 50%

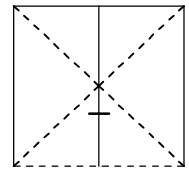
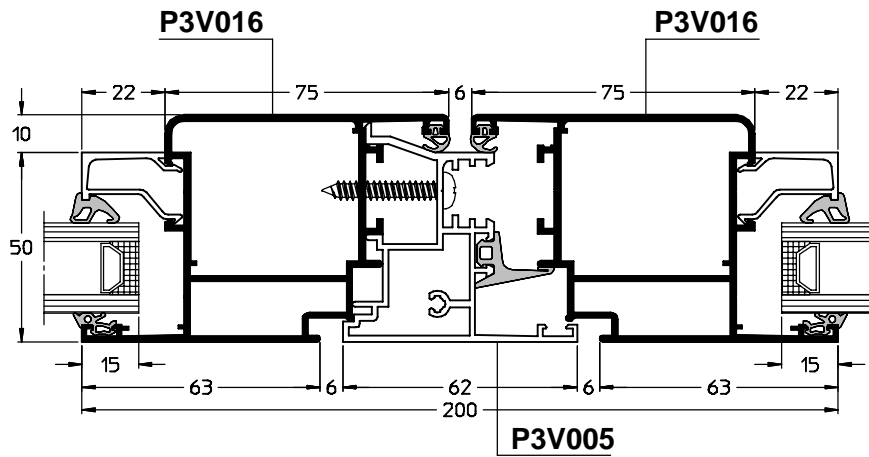
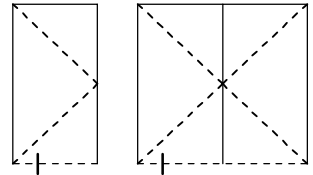
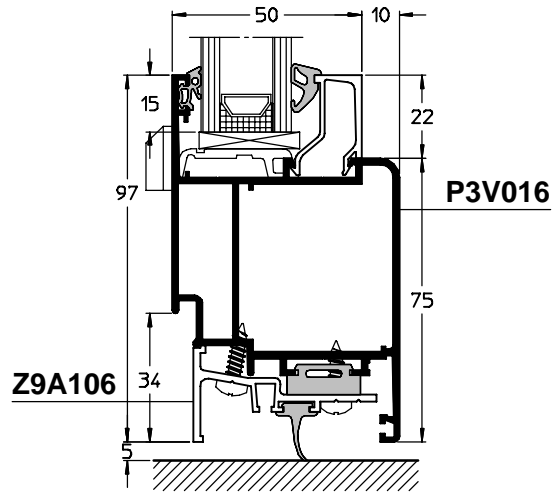

échelle : 50%

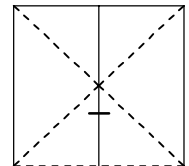
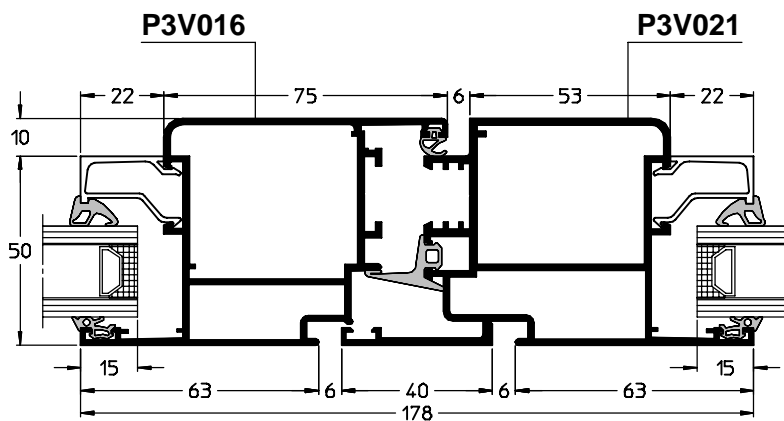

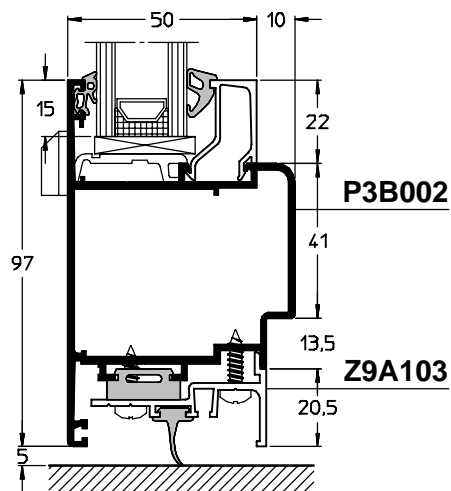
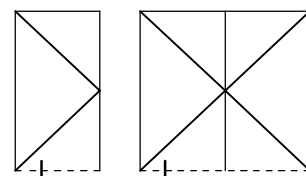

échelle : 50%

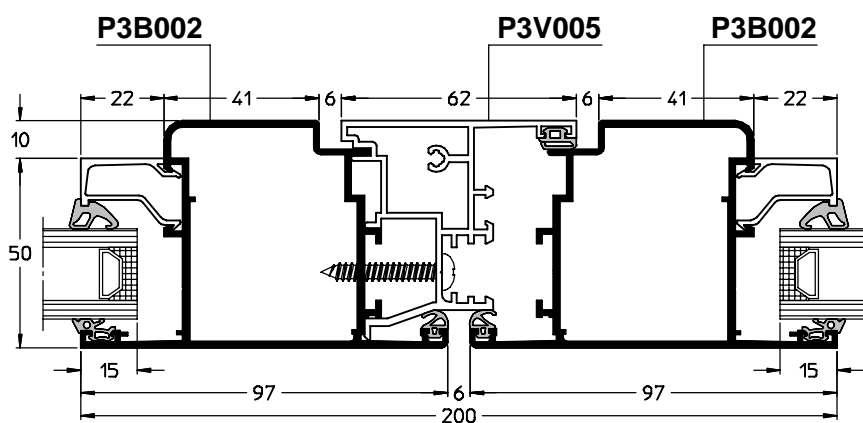
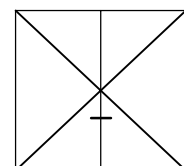

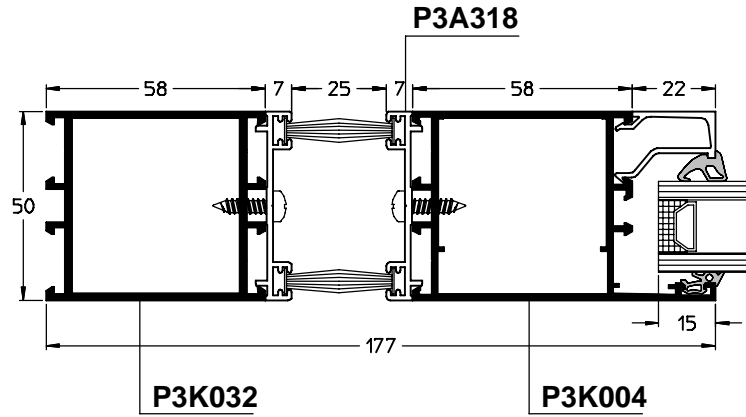
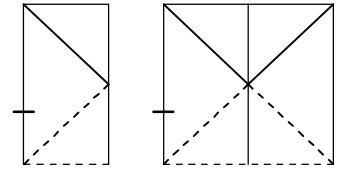

échelle : 50%

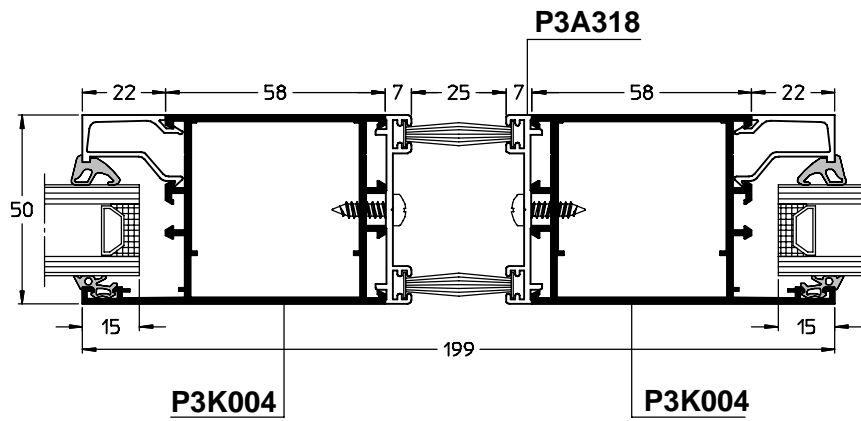
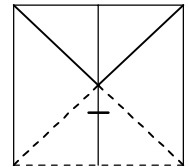

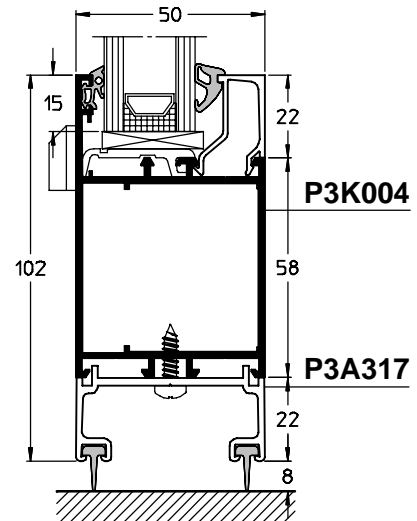
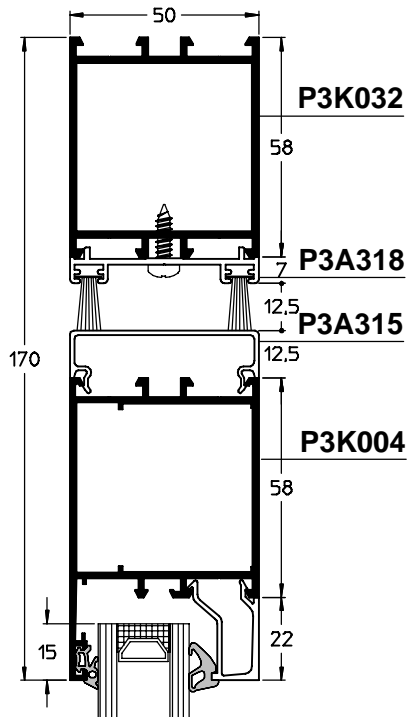
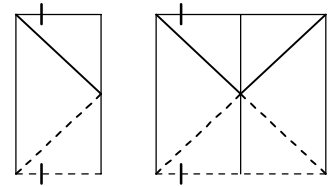

échelle : 50%

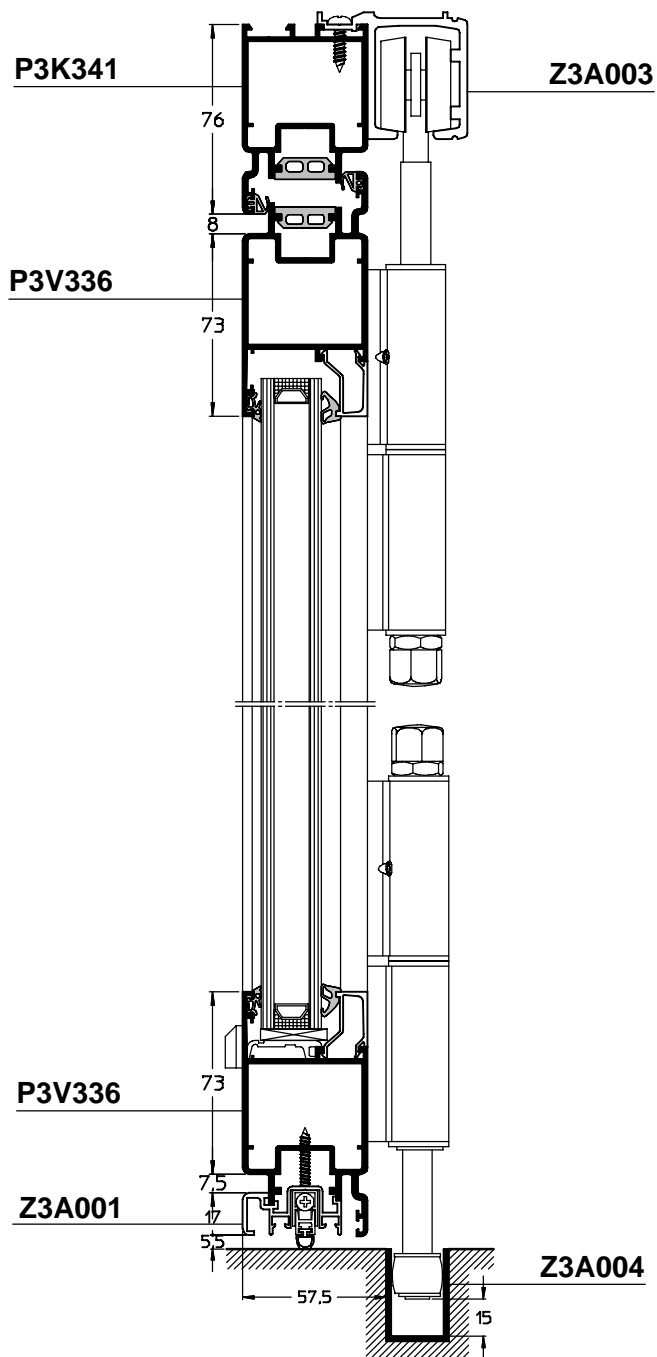
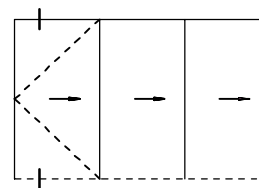

échelle : 50%

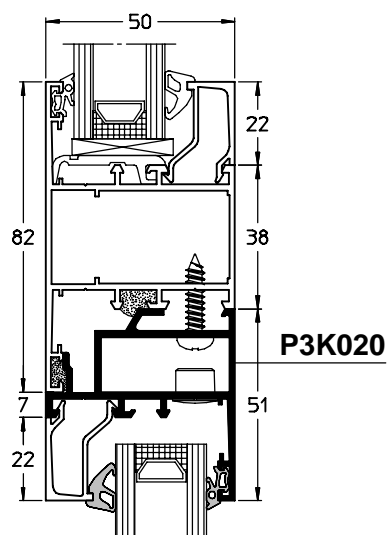
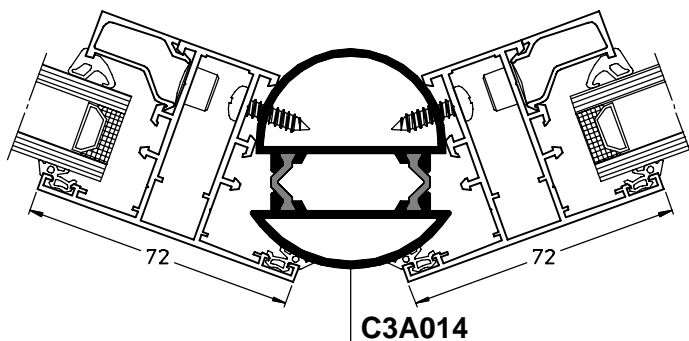

échelle : 50%

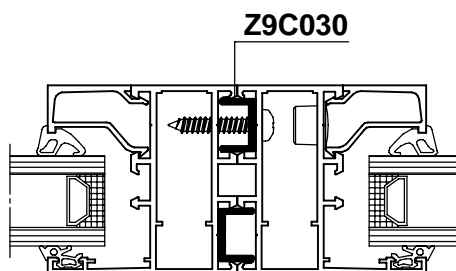
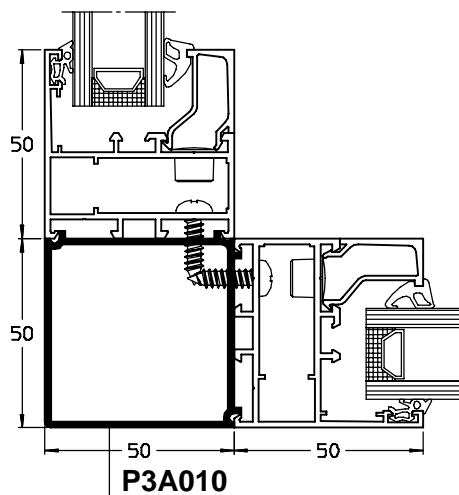

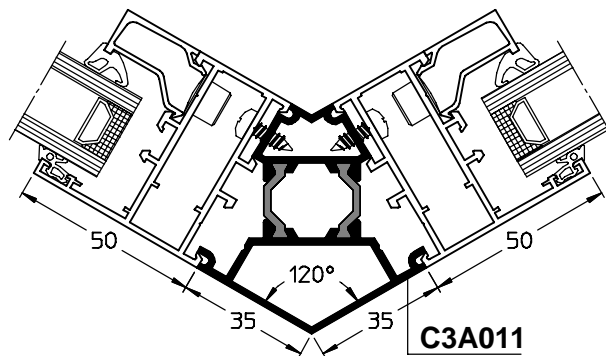

échelle : 50%

